

VSS⁺DC

from 60 to 500 kVA

Voltage Support Solution

to ensure an autonomous static power supply

Reliable power is essential to keep critical functions operational

- the **VSS⁺DC** dynamic storage solution removes restrictions linked to traditional battery use,
- the **VSS⁺DC** system provides a high level of availability for **DELPHYS MP** [Info. p. 50] or **DELPHYS MX** [Info. p. 54] Uninterruptible Power Supply units,
- the solution inverter **DELPHYS** with dynamic storage of energy **VSS⁺DC** was carried out by the partnership between **SOCOMECS** UPS and **PENTADYNE**.



VSS 010 A

Your protection for

- > Data center
- > Service sectors
- > Industry
- > Telecommunications
- > Medical applications



VSS⁺DC advantages

Dynamic energy storage technology with yet more technical advantages:

- outstanding reliability,
- reduced maintenance,
- simplified maintenance:
 - robust parts,
 - vacuum pump suitable for life,
- long service life (> 20 years),
- lax. power in min. volume,
- less floor space < 0.5 m²,
- high efficiency 99.8%,
- self-diagnostics,
- rapid recharging (few minutes),
- adjustable of voltage and current parameters,
- silent operation,
- simple operation,
- cabinet on castors for ease of installation,
- no load restrictions on ground,
- installation requiring no structural work,
- cable access via upper section,
- simplified connections,
- units coupled in parallel to increase power and back up-time,
- access front maintenance,
- environmentally-friendly.

Operating principle

- Using a very high-speed, rotating flywheel.
- Combined flywheel, shaft and generator.
- The rotating assembly is held up by electro magnetic, with no contact with other parts.
- A maintenance-free internal system vacuum annihilates friction.
- The flywheel-driven generator supplies energy to the UPS during a power failure, thus providing continuous power to the load.
- When mains power is restored, the flywheel takes as well as 20 seconds (configurable) to return to Full speed.

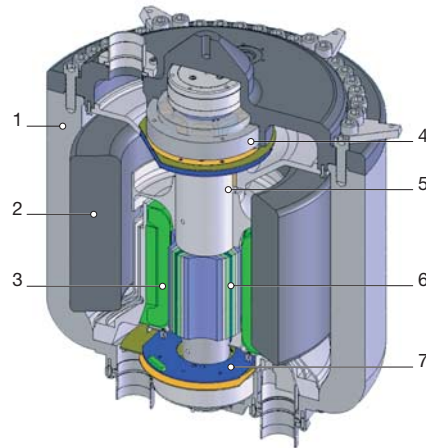

VSS 009 A

- | | |
|-------------------------------|---------------------------|
| 1. Housing | 5. Vacuum system |
| 2. Carbon-glassfibre flywheel | 6. Rotor |
| 3. Stator windings | 7. Lower magnetic bearing |
| 4. Upper magnetic bearing | |

Various configurations

Various solutions or combinations for meeting your requirements for electrical energy availability are possible depending on your operating constraints and technical environment.

- **Operation during power outages**

The **VSS⁺DC** system is connected to the DC bus; it supplies the inverter when the low-voltage system exceeds the voltage tolerances.

Thereby providing 99.5% protection against system failures.

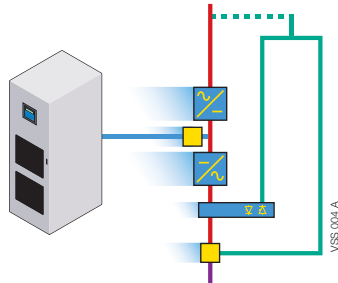

- **Working with a generator unit**

The **VSS⁺DC** supplies the inverter long enough for an emergency generator unit to take over the power supply.

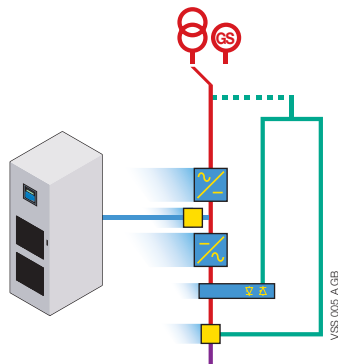

- **Working with a battery**

When connected in parallel with a battery, the **VSS⁺DC** cuts in during short power failures; battery backup is maintained and its capacity is used for major cuts. Battery life is extended by infrequent demands (life cycle).

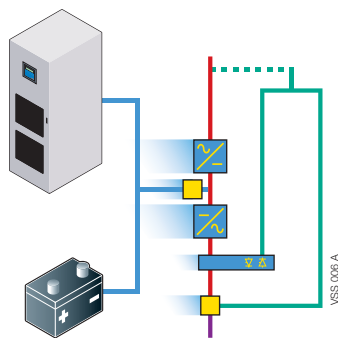

- **Working in parallel**

Several **VSS⁺DC** units connected in parallel increase power and available backup time.

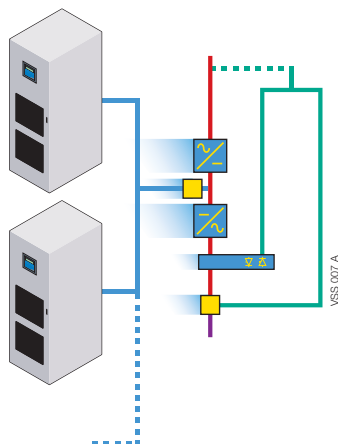

VSS⁺DC works without the constraints of batteries

- VSS⁺DC systems provide end-users with excellent results for very low operating costs.
- The VSS⁺DC systems may be used in operating conditions where battery use is impossible; the system is unaffected by ambient temperatures.

	VSS ⁺ DC	Battery
Operating costs		
Energy consumption	very high efficiency	energy consumption to maintain Float charge
Maintenance	reduced	high
Ventilation - Air conditioning	not applicable	maintaining ambient temperature increases operating costs
Technical floor space	reduced	considerable, with ground loading constraints
Service life	high (> 20 years)	frequent replacements
Autonomy availability		
Reliability	high	need for constant monitoring
Knowledge of availability	continuous	actual backup time difficult to ascertain
Life cycle (number of discharges)	no impact on service life	reduces service life
Ambient temperature	no impact	reduced temperature range
Recharge time	very low reduced (100% in about 20 seconds)	important (80% in about 8 hours)

Autonomy versus power output

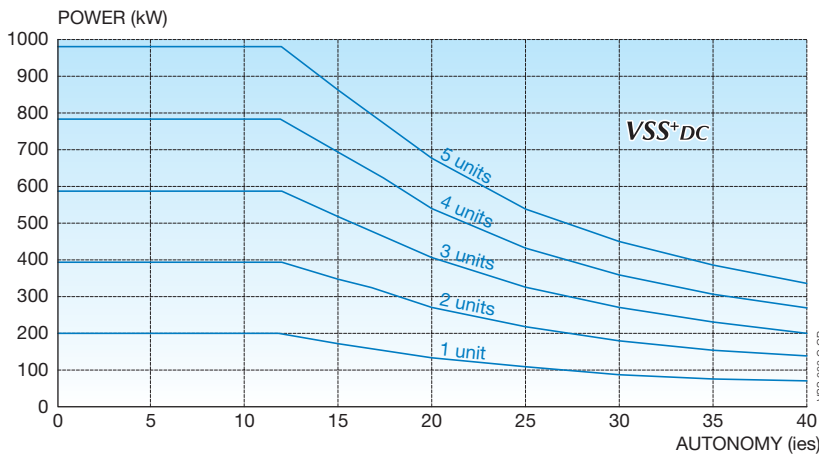

Standard equipment

- Control panel with LCD display

Additional equipment

- Emergency stop (button on door)
- Air filter

Communication option

- Remote management via Data Collection Module (DCM)
- Dry contact interface

Dimensions

Weight: 590 kg

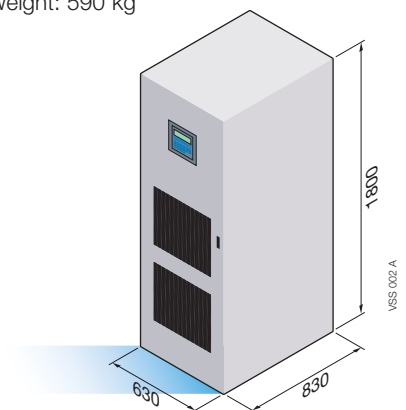

Technical data

ELECTRICAL SPECIFICATIONS

Nominal unit power	up to: 190 kW/10 seconds
Voltage (input/output)	600 V DC
Output voltage control	± 1% under static conditions
Ripple factor	< 2%
Auxiliary voltage	110/230 V AC
Auxiliary power	400 VA

ENVIRONMENT

Noise level (ISO3746)	< 45 dB
Operating temperature	- 20 °C to + 50 °C
Operating altitude	up to 3000 metres
Conformity with standards	CEE 73/23 Low voltage directive CEE 98/037 Machine directive IEC/EC 60439-1 IEC/EN 60204-1 Machine safety EN1127-1 Explosive atmospheres